

DIESEL ENGINE-GENERATOR SET

AIR CHARGE-AIR COOLING

200 kWe / 60 Hz / Standby
 180 kWe / 60 Hz / Prime
 208 - 600V



SYSTEM RATINGS

Standby	DS200D6SGA	DS200D6SDA	DS200D6SPA	DS200D6SJA	DS200D6SRA	DS200D6SNA
Voltage (L-L)	240V**	240V**	208V**	240V**	480V**	600V**
Phase	1	1	3	3	3	3
PF	1.0	1.0	0.8	0.8	0.8	0.8
Hz	60	60	60	60	60	60
kW	200	200	200	200	200	200
kVA	200	200	250	250	250	250
AMPS	833	833	694	601	301	241
skVA@30%						
Voltage Dip	250	370	370	370	495	510
Generator Model*	432CSL6212	432PSL6228	431CSL6206	431CSL6206	431CSL6206	431PSL6243
Temp Rise	130°C/27°C	130°C/27°C	130°C/27°C	130°C/27°C	130°C/27°C	125°C/40°C
Connection	12 LEAD ZIG-ZAG	4 LEAD	12 LEAD LOW WYE	12 LEAD HI DELTA	12 LEAD HI WYE	4 LEAD WYE

Prime	DP180D6SGA	DP180D6SDA	DP180D6SPA	DP180D6SJA	DP180D6SRA	DP180D6SNA
Voltage (L-L)	240V**	240V**	208V**	240V**	480V**	600V**
Phase	C/F	C/F	3	3	3	3
PF	C/F	C/F	0.8	0.8	0.8	0.8
Hz	C/F	C/F	60	60	60	60
kW	C/F	C/F	180	180	180	180
kVA	C/F	C/F	225	225	225	225
AMPS	C/F	C/F	625	541	271	217
skVA@30%						
Voltage Dip	C/F	C/F	280	280	495	510
Generator Model*	C/F	C/F	431CSL6208	431CSL6208	431CSL6206	431PSL6243
Temp Rise	C/F	C/F	105°C/40°C	105°C/40°C	105°C/40°C	105°C/40°C
Connection	C/F	C/F	12 LEAD LOW WYE	12 LEAD HI DELTA	12 LEAD HI WYE	4 LEAD WYE

** UL2200 Offered

STANDARD FEATURES

- // EPA Tier 3 Certified
- // Engine-Generator Set Tested to ISO 8528-5 for Transient Response
- // UL2200 Listed, CSA Certified – Offered
- // Accepts Rated Load in One Step Per NFPA 110
- // All engine-generator sets are prototype and factory tested
- // MTU Onsite Energy is a single source supplier
- // Global Product Support
- // 2 Year Standard Warranty
- // 6068HF485 Diesel Engine
 - 6.8 Liter Displacement
 - 4-Cycle
- // Complete Range of Accessories
- // Engine-generator resilient mounted
- // Generator
 - Brushless, Rotating Field Generator
 - PMG (Permanent Magnet Generator) supply to regulator
 - 300% Short Circuit Capability
 - 2/3 Pitch Windings
- // Digital Control Panel(s)
 - UL Recognized, CSA Certified, NFPA 110
 - Complete System Metering
 - LCD Display
- // Cooling System
 - Integral Set-Mounted
 - Engine Driven Fan

STANDARD EQUIPMENT

// Engine

Air Cleaners
 Oil Pump
 Full Flow Oil Filter
 Fuel Filter with Water Separator
 Jacket Water Pump
 Thermostat
 Exhaust Manifold – Dry
 Blower Fan & Fan Drive
 Radiator – Unit Mounted
 Electric Starting Motor – 12V
 Governor – Electronic Isochronous
 Base – Formed Steel
 SAE Flywheel & Bell Housing
 Charging Alternator – 12V
 Battery Box & Cables
 Flexible Fuel Connectors
 Flexible Exhaust Connection
 EPA Certified Engine

// Generator

NEMA MG1, IEEE and ANSI standards compliance for temperature rise and motor starting
 Sustained short circuit current of up to 300% of the rated current for up to 10 seconds
 Self-Ventilated and Drip-Proof
 Superior Voltage Waveform
 Digital, Solid State, Volts-per-Hertz Regulator
 No Load to Full Load Regulation

Brushless Alternator with Brushless Pilot Exciter
 4 Pole, Rotating Field
 130°C Maximum Standby Temperature Rise
 1 Bearing, Sealed
 Flexible Coupling
 Full Amortisseur Windings
 125% Rotor Balancing
 3-Phase Voltage Sensing
 ±1% Voltage Regulation
 100% of Rated Load – One Step
 3% Maximum Harmonic Content

// Digital Control Panel(s)

Digital Metering
 Engine Parameters
 Generator Protection Functions
 Engine Protection
 SAE J1939 Engine ECU Communications
 Windows-Based Software
 Multilingual Capability
 Remote Communications to our RDP-110 Remote Annunciator
 16 Programmable Contact Inputs
 Up to 11 Contact Outputs
 UL Recognized, CSA Certified, CE Approved
 Event Recording
 IP 54 Front Panel Rating with Integrated Gasket
 NFPA110 Compatible

APPLICATION DATA

// Engine

Manufacturer	John Deere
Model	6068HF485
Type	4-Cycle
Arrangement	6-Inline
Displacement: L (in ³)	6.8 (415)
Bore: cm (in)	10.6 (4.2)
Stroke: cm (in)	12.7 (5)
Compression Ratio	17:1
Rated RPM	1,800
Engine Governor	JDEC
Maximum Power: Standby: kWm (bhp)	235 (315)
Maximum Power: Prime: kWm (bhp)	214 (286)
Speed Regulation	±0.25%
Air Cleaner	Dry

// Liquid Capacity (Lubrication)

Total Oil System: L (gal)	32.2 (8.5)
Engine Jacket Water Capacity: L (gal)	11.9 (3.3)
System Coolant Capacity: L (gal)	29.3 (7.75)

// Electrical

Electric Volts DC	12
Cold Cranking Amps Under -17.8°C (0°F)	800

// Fuel System

Fuel Supply Connection Size	3/8" NPT
Fuel Return Connection Size	3/8" NPT
Maximum Fuel Lift: m (ft)	2 (6.7)
Recommended Fuel	Diesel #2
Total Fuel Flow: L/hr (gal/hr)	93 (24.5)

// Fuel Consumption

	STANDBY	PRIME
At 100% of Power Rating: L/hr (gal/hr)	58.6 (15.5)	51.9 (13.5)
At 75% of Power Rating: L/hr (gal/hr)	42.9 (11.3)	40.5 (10.7)
At 50% of Power Rating: L/hr (gal/hr)	30 (7.9)	27.6 (7.3)

// Cooling - Radiator System

	STANDBY	PRIME
Ambient Capacity of Radiator: °C (°F)	50 (122)	50 (122)
Maximum Restriction of Cooling Air, Intake, and Discharge Side of Rad.: kPa (in. H ₂ O)	0.12 (0.5)	0.12 (0.5)
Water Pump Capacity: L/min (gpm)	265 (70)	265 (70)
Heat Rejection to Coolant: kW (BTUM)	94.9 (5,404)	83.7 (4,766)
Heat Rejection to Air to Air: kW (BTUM)	57 (3,264)	40 (2,298)
Heat Radiated to Ambient: kW (BTUM)	30 (1,703)	25.5 (1,453)

// Air Requirements

	STANDBY	PRIME
Aspirating: *m ³ /min (SCFM)	17.5 (619)	14.7 (520)
Air Flow Required for Rad.		
Cooled Unit: *m ³ /min (SCFM)	412 (14,537)	412 (14,537)
Air Flow Required for Heat Exchanger/Remote Rad. based on 25°F Rise: *m ³ /min (SCFM)	109 (3,842)	93 (3,277)

* Air density = 1.184 kg/m³ (0.0739 lbm/ft³)

// Exhaust System

	STANDBY	PRIME
Gas Temp. (Stack): °C (°F)	485 (905)	528 (982)
Gas Volume at Stack		
Temp: m ³ /min (CFM)	42.9 (1,514)	38.8 (1,371)
Maximum Allowable		
Back Pressure: kPa (in. H ₂ O)	10 (40)	10 (40)

WEIGHTS AND DIMENSIONS

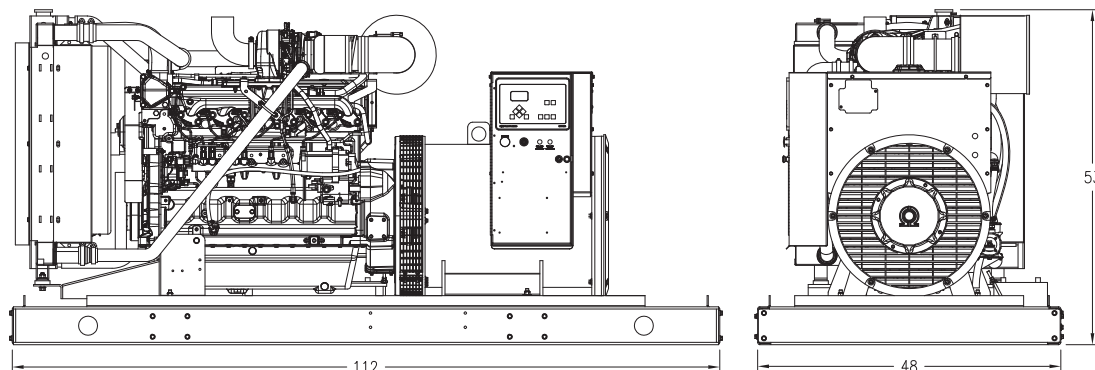

Drawing above for illustration purposes only, based on standard open power 480 volt engine-generator set. Lengths may vary with other voltages. Do not use for installation design. See website for unit specific template drawings.

System	Dimensions (L x W x H)	Weight (less tank)
OPU	2,845 x 1,219 x 1,346 mm (112 x 48 x 53 in)	1,751 kg (3,860 lb)

Weights and dimensions are based on open power units and are estimates only. Consult the factory for accurate weights and dimensions for your specific engine-generator set.

SOUND DATA

Unit Type	Standby Full Load	Prime Full Load
Level 0: Open Power Unit (dBA)	87.2	87.2

Sound data is provided at 7 m (23 ft). Engine-generator set tested in accordance with ISO 8528-10 and with infinite exhaust.

EMISSIONS DATA

NO _x + NMHC	CO	PM
2.86	0.78	0.104

All units are in g/hp-hr and are EPA D2 cycle values.

Emission levels of the engine may vary as a function of ambient temperature, barometric pressure, humidity, fuel type and quality, installation parameters, measuring instrumentation, etc. The data provided are laboratory results from one engine representing this rating. The data was obtained under controlled environmental conditions with calibrated instrumentation traceable to the United States National Bureau of Standards and in compliance with US EPA regulations found within 40 CFR Part 89. The weighted cycle value from each engine is guaranteed to be below the US EPA Standards at the US EPA defined conditions.

RATING DEFINITIONS AND CONDITIONS

- // Standby ratings apply to installations served by a reliable utility source. The standby rating is applicable to varying loads for the duration of a power outage. No overload capability for this rating. Ratings are in accordance with ISO-3046/1, BS 5514, AS 2789, and DIN 6271.
- // Prime power ratings apply to installations where utility power is unavailable or unreliable. At varying load, the number of generator set operating hours is unlimited. A 10% overload capacity is available for one hour in twelve. Ratings are in accordance with ISO-8528/1, overload power in accordance with ISO-3046/1, BS 5514, AS 2789, and DIN 6271.
- // Deration Factor:
 - Altitude:** Consult your local MTU Onsite Energy Power Generation Distributor for altitude derations.
 - Temperature:** Consult your local MTU Onsite Energy Power Generation Distributor for temperature derations.

Materials and specifications subject to change without notice.

C/F = Consult Factory/MTU Onsite Energy Distributor