

GAS ENGINE-GENERATOR SET

100-GC6NLT1

100 kWe / 60 Hz / Standby
208 - 600V



SYSTEM RATINGS

Standby

Voltage (L-L)	240V	240V	208V	240V	480V	600V
Phase	1	1	3	3	3	3
PF	1.0	1.0	0.8	0.8	0.8	0.8
Hz	60	60	60	60	60	60
Natural Gas						
Ratings: Amps	354	354	323	280	140	112
Natural Gas						
Ratings: kW/kVA	85/85	85/85	93/116.25	93/116.25	93/116.25	93/116.25
LP Gas						
Ratings: Amps	396	396	347	301	150	120
LP Gas						
Ratings: kW/kVA	95/95	95/95	100/125	100/125	100/125	100/125
skVA@30%						
Voltage Dip	136	195	250	250	273	273
Generator Model*	431CSL6204	431PSL6224	363CSL1607	363CSL1607	362CSL1606	362PSL1636
Temp Rise	130°C/27°C	125°C/40°C	130°C/27°C	130°C/27°C	130°C/27°C	125°C/40°C
Connection	12 LEAD ZIG-ZAG	4 LEAD	12 LEAD LOW WYE	12 LEAD HI DELTA	12 LEAD HI WYE	4 LEAD WYE

* The Generator Model Number identified in the table is for standard C Series Configuration. Consult the factory for alternate configuration.

STANDARD FEATURES

- // Engine-Generator Set Tested to ISO 8528-5 for Transient Response
- // UL2200 Listed, CSA Certified – Offered
- // Accepts Rated Load in One Step Per NFPA 110
- // All engine-generator sets are prototype and factory tested
- // MTU Onsite Energy is a single source supplier
- // Global Product Support
- // 2 Year Standard Warranty
- // 8.1 L Engine
 - 8.1 Liter Displacement
 - 4-Cycle
- // 3-Way Catalyst
- // Complete Range of Accessories
- // Engine-generator resilient mounted
- // Generator
 - Brushless, Rotating Field Generator
 - PMG (Permanent Magnet Generator) supply to regulator
 - 300% Short Circuit Capability
 - 2/3 Pitch Windings
 - Standard for 570 frame and larger
 - Optional for 430 frame and smaller
- // Digital Control Panel(s)
 - UL Recognized, CSA Certified, NFPA 110
 - Complete System Metering
 - LCD Display
- // Cooling System
 - Integral Set-Mounted
 - Engine Driven Fan

STANDARD EQUIPMENT

// Engine

Air Cleaner
 Oil Pump
 Full Flow Oil Filter
 Jacket Water Pump
 Thermostat
 Exhaust Manifold - Dry
 Blower Fan & Fan Drive
 Radiator - Unit Mounted
 Electric Starting Motor - 12V
 Governor - Electronic Isochronous
 Base - Formed Steel
 SAE Flywheel & Bell Housing
 Charging Alternator - 12V
 Battery Box & Cables
 Flexible Fuel Connectors
 Flexible Exhaust Connection
 EPA Certified Engine

// Generator

NEMA MG1, IEEE and ANSI standards compliance for temperature rise and motor starting
 Sustained short circuit current of up to 300% of the rated current for up to 10 seconds
 Self-Ventilated and Drip-Proof
 Superior Voltage Waveform
 Digital, Solid State, Volts-per-Hertz Regulator
 No Load to Full Load Regulation
 Brushless Alternator with Brushless Pilot Exciter
 4 Pole, Rotating Field
 130°C Maximum Standby Temperature Rise
 1 Bearing, Sealed
 Flexible Coupling
 Full Amortisseur Windings
 125% Rotor Balancing
 3-Phase Voltage Sensing
 ±1% Voltage Regulation
 100% of Rated Load - One Step
 3% Maximum Harmonic Content

// Digital Control Panel(s)

Digital Metering
 Engine Parameters
 Generator Protection Functions
 Engine Protection
 SAE J1939 Engine ECU Communications
 Windows-Based Software
 Multilingual Capability
 Remote Communications to our RDP-110 Remote Annunciator
 16 Programmable Contact Inputs
 Up to 11 Contact Outputs
 UL Recognized, CSA Certified, CE Approved
 Event Recording
 IP 54 Front Panel Rating with Integrated Gasket
 NFPA110 Compatible

APPLICATION DATA

// Engine

Manufacturer	GM
Model	8.1L
Type	4-Cycle
Arrangement	8-V
Displacement: L (in ³)	8.1 (496)
Bore: cm (in)	10.8 (4.25)
Stroke: cm (in)	11.1 (4.37)
Compression Ratio	9.1:1
Rated RPM	1,800
Engine Governor	Bosch
Maximum Power: Standby: kWm (bhp)	122.6 (164.4)
Speed Regulation	C/F
Air Cleaner	Dry

// Liquid Capacity (Lubrication)

Total Oil System: L (gal)	7.6 (2)
Engine Jacket Water Capacity: L (gal)	13.7 (3.6)
System Coolant Capacity: L (gal)	31.8 (8.4)

// Electrical

Electric Volts DC	12
Cold Cranking Amps Under -17.8°C (0°F)	600

// Fuel Inlet

Fuel Supply Connection Size	1 1/2" NPT
Fuel Supply Pressure: mm H ₂ O (in. H ₂ O)	178-279 (7-11)

// Fuel Consumption (NG-1000 BTU/ft³ / LP-2500 BTU/ft³)

	NG	LPG
At 100% of Power Rating: m ³ /hr (ft ³ /hr)	33.3 (1,177)	14.7 (520)
At 75% of Power Rating: m ³ /hr (ft ³ /hr)	25.2 (890)	11.1 (394)
At 50% of Power Rating: m ³ /hr (ft ³ /hr)	17.6 (621)	7.8 (275)

// Cooling - Radiator System

Ambient Capacity of Radiator: °C (°F)	50 (122)
Maximum Restriction of Cooling Air, Intake, and Discharge Side of Rad.: kPa (in. H ₂ O)	0.12 (0.5)
Water Pump Capacity: L/min (gpm)	140.1 (37)
Heat Rejection to Coolant: kW (BTUM)	72.8 (4,141)
Heat Radiated to Ambient: kW (BTUM)	66 (3,752)

// Air Requirements

Aspirating: *m ³ /min (SCFM)	7.3 (258.3)
Air Flow Required for Rad.	
Cooled Unit: *m ³ /min (SCFM)	284 (10,030)
Air Flow Required for Heat Exchanger/Remote Rad. based on 25°F Rise: *m ³ /min (SCFM)	239.6 (8,462.7)

* Air density = 1.184 kg/m³ (0.0739 lbm/ft³)

// Exhaust System

Gas Temp. (Stack): °C (°F)	704.4 (1,300)
Gas Volume at Stack Temp: m ³ /min (CFM)	23.6 (834)
Maximum Allowable Back Pressure: kPa (in. H ₂ O)	10 (40)

WEIGHTS AND DIMENSIONS

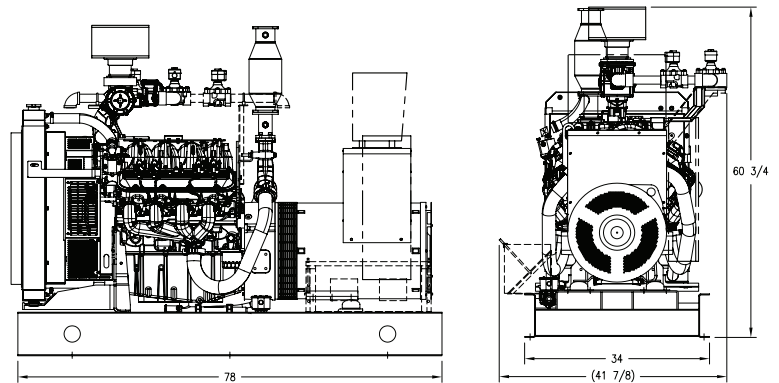

Drawing above for illustration purposes only, based on standard open power 480 volt engine-generator set. Lengths may vary with other voltages. Do not use for installation design. See website for unit specific template drawings.

System	Dimensions (L x W x H)	Weight (dry)
OPU	1,981 x 864 x 1,543 mm (78 x 34 x 60.75 in)	976 kg (2,150 lb)

Weights and dimensions are based on open power units and are estimates only. Consult the factory for accurate weights and dimensions for your specific engine-generator set.

SOUND DATA

Unit Type	Standby Full Load
OPU (dBA)	C/F
WPE - No Sound Attenuation (dBA)	C/F
CQE (dBA)	C/F

Sound data is provided at 7 m (23 ft).

EMISSIONS DATA

Fuel Type	THC + NO _x	CO
Natural Gas	0.23	0.31
Liquid Propane	0.134	0.79

All units are in g/hp-hr.

Engine meets EPA 40 CFR Part 60/1048 specifications.

RATING DEFINITIONS AND CONDITIONS

// Standby ratings apply to installations served by a reliable utility source. The standby rating is applicable to varying loads for the duration of a power outage. No overload capability for this rating. Ratings are in accordance with ISO-3046/1, BS 5514, AS 2789, and DIN 6271.

// Deration Factor:

Altitude: Consult your local MTU Onsite Energy Power Generation Distributor for altitude derations.

Temperature: Consult your local MTU Onsite Energy Power Generation Distributor for temperature derations.

Materials and specifications subject to change without notice.

C/F = Consult Factory/MTU Onsite Energy Distributor