

# DIESEL ENGINE-GENERATOR SET

## 200-JS6DT3

200 kWe / 60 Hz / Standby  
208 - 600V



### SYSTEM RATINGS

#### Standby

Voltage (L-L)	240V**	240V**	208V**	240V**	480V**	600V**
Phase	1	1	3	3	3	3
PF	1.0	1.0	0.8	0.8	0.8	0.8
Hz	60	60	60	60	60	60
kW	200	200	200	200	200	200
kVA	200	200	250	250	250	250
AMPS	833	833	694	601	301	241
skVA@30%						
Voltage Dip	520	364	370	491	491	510
Generator Model	432CSL6212	432CSL6228	431CSL6206	431CSL6206	431CSL6206	431PSL6243
Temp Rise	130°C/27°C	130°C/27°C	130°C/27°C	130°C/27°C	130°C/27°C	125°C/40°C
Connection	12 LEAD ZIG-ZAG	4 LEAD	12 LEAD LOW WYE	12 LEAD HI DELTA	12 LEAD HI WYE	4 LEAD WYE

\*\* UL2200 Offered

### STANDARD FEATURES

- // EPA Tier 3 Certified
- // Engine-Generator Set Tested to ISO 8528-5 for Transient Response
- // UL2200, CSA Listing Offered
- // Accepts Rated Load in One Step Per NFPA 110
- // All engine-generator sets are prototype and factory tested
- // MTU Onsite Energy is a single source supplier
- // Global Product Support
- // 2 Year Standard Warranty
- // 6068HF485 Diesel Engine
  - 6.8 Liter Displacement
  - 4-Cycle
- // Complete Range of Accessories
- // Permanent Magnet Generator (PMG)
  - Brushless, Rotating Field
  - 300% Short Circuit Capability
  - 2/3 Pitch Windings
  - Standard for 570 frame and larger
  - Optional for 430 frame and smaller
- // Digital Control Panel(s)
  - UL Recognized, cULus, NFPA 110
  - Complete System Metering
  - LCD Display
- // Cooling System
  - Integral Set-Mounted
  - Engine Driven Fan

## STANDARD EQUIPMENT

### // Engine

Air Cleaner  
 Oil Pump  
 Full Flow Oil Filter  
 Fuel Filter with Water Separator  
 Jacket Water Pump  
 Closed Crankcase Ventilation  
 Thermostats  
 Exhaust Manifold - Dry  
 Blower Fan & Fan Drive  
 Radiator - Unit Mounted  
 Electric Starting Motor - 12V  
 Governor - Electronic Isochronous  
 Base - Formed Steel  
 SAE Flywheel & Bell Housing  
 Charging Alternator - 12V  
 Battery Box & Cables  
 Flexible Fuel Connectors  
 Flexible Exhaust Connection  
 EPA Certified Engine

### // Generator

NEMA MG1, IEEE and ANSI standards compliance for temperature rise and motor starting  
 Sustained short circuit current of up to 300% of the rated current for up to 10 seconds  
 Self-Ventilated and Drip-Proof  
 Superior Voltage Waveform  
 Digital, Solid State, Volts-per-Hertz Regulator  
 No Load to Full Load Regulation  
 Brushless Alternator with Brushless Pilot Exciter  
 4 Pole, Rotating Field  
 130°C Standby Temperature Rise  
 1 Bearing, Sealed  
 Flexible Coupling  
 Full Amortisseur Windings  
 125% Rotor Balancing  
 3-Phase Voltage Sensing  
 ±1% Voltage Regulation  
 100% of Rated Load - One Step  
 3% Maximum Harmonic Content

### // Digital Control Panel(s)

Digital Metering  
 Engine Parameters  
 Generator Protection Functions  
 Engine Protection  
 SAE J1939 Engine ECU Communications  
 Windows-Based Software  
 Multilingual Capability  
 Remote Communications to our RDP-110 Remote Annunciator  
 16 Programmable Contact Inputs  
 7 Contact Outputs  
 UL Recognized, cULus, CE Approved  
 Event Recording  
 IP 54 Front Panel Rating with Integrated Gasket  
 NFPA110 Level Compatible

### // Additional Features

Oil Drain Extension & S/O Valve  
 Flexible Fuel Connector  
 Battery Cables  
 Vibration Isolation Pads  
 Jacket Water Heater: -20° F  
 Mainline Circuit Breaker  
 UL2200 Listed  
 Steel Sub-Base  
 Radiator Duct Flange (OPU)  
 Lube Oil & Antifreeze  
 Operator's and Owner's Manual  
 2 Year/3000 Hour Warranty  
 Factory Tested at 0.8 PF (3 PH)

### // Optional Features

Battery Charger: 6 Amp or 10 Amp  
 Battery: 12 Volt w/ Rack  
 Circuit Breaker: Standard or 100%  
 Muffler (OPU only)  
 Sub-Base Fuel Tank w/ Electrical Stub-Up Area  
 Weatherproof Enclosure  
 Sound Attenuation  
 - 1 1/2" Foam  
 - Sound Scoops  
 Remote Annunciator  
 Isochronous Governor

## APPLICATION DATA

### // Engine

Manufacturer	John Deere
Model	6068HF485
Type	4-Cycle
Arrangement	6-Inline
Displacement: L (in <sup>3</sup> )	6.8 (415)
Bore: cm (in)	10.6 (4.2)
Stroke: cm (in)	12.7 (5)
Compression Ratio	17:1
Rated RPM	1,800
Engine Governor	JDEC
Maximum Power: Standby: kWm (bhp)	235 (315)
Speed Regulation	±1%
Air Cleaner	Dry

### // Liquid Capacity (Lubrication)

Total Oil System: L (gal)	32.2 (8.5)
Engine Jacket Water Capacity: L (gal)	11.9 (3.3)
System Coolant Capacity: L (gal)	29.3 (7.75)

### // Electrical

Electric Volts DC	12
Cold Cranking Amps Under -17.8°C (0°F)	800

### // Fuel System

Fuel Supply Connection Size	3/8" NPT
Fuel Return Connection Size	3/8" NPT
Maximum Fuel Lift: m (ft)	2 (6.7)
Recommended Fuel	Diesel #2
Total Fuel Flow: L/hr (gal/hr)	93 (24.5)

### // Fuel Consumption

At 100% of Power Rating: L/hr (gal/hr)	58.6 (15.5)
At 75% of Power Rating: L/hr (gal/hr)	42.9 (11.3)
At 50% of Power Rating: L/hr (gal/hr)	30 (7.9)

### // Cooling - Radiator System

Ambient Capacity of Radiator: °C (°F)	50 (122)
Maximum Restriction of Cooling Air, Intake, and Discharge Side of Rad.: kPa (in. H <sub>2</sub> O)	0.12 (0.5)
Water Pump Capacity: L/min (gpm)	265 (70)
Heat Rejection to Coolant: kW (BTUM)	94.9 (5,404)
Heat Radiated to Air to Air: kW (BTUM)	57 (3,264)
Heat Radiated to Ambient: kW (BTUM)	27 (1,530)

### // Air Requirements

Aspirating: *m <sup>3</sup> /min (SCFM)	17.5 (619)
Air Flow Required for Rad.	
Cooled Unit: *m <sup>3</sup> /min (SCFM)	502 (17,712)
Air Flow Required for Heat Exchanger/Remote Rad. based on 25°F Rise: *m <sup>3</sup> /min (SCFM)	98 (3,451)

\* Air density = 1.184 kg/m<sup>3</sup> (0.0739 lbm/ft<sup>3</sup>)

### // Exhaust System

Gas Temp. (Stack): °C (°F)	485 (905)
Gas Volume at Stack Temp: m <sup>3</sup> /min (CFM)	42.9 (1,514)
Maximum Allowable Back Pressure: kPa (in. H <sub>2</sub> O)	10 (40)

## WEIGHTS AND DIMENSIONS

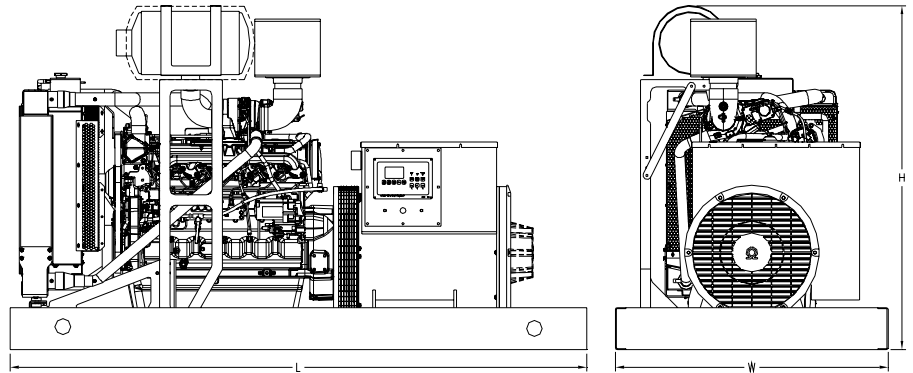

Drawing above for illustration purposes only, based on standard open power 480 volt engine-generator set. Lengths may vary with other voltages. Do not use for installation design. See website for unit specific template drawings.

System	Dimensions (L x W x H)	Height w/Tank 24hr.	Weight (less tank)
OPU	2,790 x 1,320 x 1,670 mm (110 x 52 x 65.6 in)	2,480 mm (97.6 in)	1,818 kg (4,007 lb)
EPU	2,790 x 1,320 x 1,980 mm (110 x 52 x 77.9 in)	2,790 mm (109.9 in)	2,181 kg (4,808 lb)

Weights and dimensions are based on open power units and are estimates only. Consult the factory for accurate weights and dimensions for your specific engine-generator set.

## SOUND DATA

Unit Type	Standby Full Load	Standby No Load
OPU w/Critical Grade Muffler (dBA)	93	85
Sound Attenuated Enclosure (dBA)	85	77

Sound data is provided at 7 m (23 ft).

## EMISSIONS DATA

NO <sub>x</sub> + NMHC	CO	PM
2.76	0.43	0.059

### All units are in g/hp-hr and are EPA D2 cycle values.

Emission levels of the engine may vary as a function of ambient temperature, barometric pressure, humidity, fuel type and quality, installation parameters, measuring instrumentation, etc. The data provided are laboratory results from one engine representing this rating. The data was obtained under controlled environmental conditions with calibrated instrumentation traceable to the United States National Bureau of Standards and in compliance with US EPA regulations found within 40 CFR Part 89. The weighted cycle value from each engine is guaranteed to be below the US EPA Standards at the US EPA defined conditions.

## RATING DEFINITIONS AND CONDITIONS

// Standby ratings apply to installations served by a reliable utility source. The standby rating is applicable to varying loads for the duration of a power outage. No overload capability for this rating. Ratings are in accordance with ISO-3046/1, BS 5514, AS 2789, and DIN 6271.

// Deration Factor:

**Altitude:** 0.5% per 305 m (1,000 ft) above 1,524 m (5,000 ft) and 4% per 305 m (1,000 ft) above 3,048 m (10,000 ft). Consult your local MTU Onsite Energy Power Generation Distributor for other altitudes.

**Temperature:** 0.5% per 5.5°C (10°F) above 25°C (77°F).

Materials and specifications subject to change without notice.

C/F = Consult Factory/MTU Onsite Energy Distributor