

DIESEL ENGINE-GENERATOR SET

125-JS6DT3

125 kWe / 60 Hz / Standby
208 - 600V



SYSTEM RATINGS

Standby

Voltage (L-L)	240V**	240V**	208V**	240V**	480V**	600V**
Phase	1	1	3	3	3	3
PF	1.0	1.0	0.8	0.8	0.8	0.8
Hz	60	60	60	60	60	60
kW	125	125	125	125	125	125
kVA	125	125	156.25	156.25	156.25	156.25
AMPS	521	521	434	376	188	150
skVA@30%						
Voltage Dip	136	195	250	250	330	335
Generator Model	431CSL6204	431CSL6224	363CSL1607	363CSL1607	363CSL1607	363PSL1658
Temp Rise	130°C/27°C	130°C/27°C	130°C/27°C	130°C/27°C	130°C/27°C	125°C/40°C
Connection	12 LEAD ZIG-ZAG	4 LEAD	12 LEAD LOW WYE	12 LEAD HI DELTA	12 LEAD HI WYE	4 LEAD WYE

** UL2200 Offered

STANDARD FEATURES

- // EPA Tier 3 Certified
- // Engine-Generator Set Tested to ISO 8528-5 for Transient Response
- // UL2200, CSA Listing Offered
- // Accepts Rated Load in One Step Per NFPA 110
- // All engine-generator sets are prototype and factory tested
- // MTU Onsite Energy is a single source supplier
- // Global Product Support
- // 2 Year Standard Warranty
- // 6068HF285 Diesel Engine
 - 6.8 Liter Displacement
 - 4-Cycle
- // Complete Range of Accessories
- // Permanent Magnet Generator (PMG)
 - Brushless, Rotating Field
 - 300% Short Circuit Capability
 - 2/3 Pitch Windings
 - Standard for 570 frame and larger
 - Optional for 430 frame and smaller
- // Digital Control Panel(s)
 - UL Recognized, cULus, NFPA 110
 - Complete System Metering
 - LCD Display
- // Cooling System
 - Integral Set-Mounted
 - Engine Driven Fan

STANDARD EQUIPMENT

// Engine

Air Cleaner
 Oil Pump
 Full Flow Oil Filter
 Fuel Filter with Water Separator
 Jacket Water Pump
 Thermostats
 Exhaust Manifold - Dry
 Blower Fan & Fan Drive
 Radiator - Unit Mounted
 Electric Starting Motor - 12V
 Governor - Electronic Isochronous
 Base - Formed Steel
 SAE Flywheel & Bell Housing
 Charging Alternator - 12V
 Battery Box & Cables
 Flexible Fuel Connectors
 Flexible Exhaust Connection
 EPA Certified Engine

// Generator

NEMA MG1, IEEE and ANSI standards compliance for temperature rise and motor starting
 Sustained short circuit current of up to 300% of the rated current for up to 10 seconds
 Self-Ventilated and Drip-Proof
 Superior Voltage Waveform
 Digital, Solid State, Volts-per-Hertz Regulator
 No Load to Full Load Regulation
 Brushless Alternator with Brushless Pilot Exciter
 4 Pole, Rotating Field
 130°C Standby Temperature Rise
 1 Bearing, Sealed
 Flexible Coupling
 Full Amortisseur Windings
 125% Rotor Balancing
 3-Phase Voltage Sensing
 ±1% Voltage Regulation
 100% of Rated Load - One Step
 3% Maximum Harmonic Content

// Digital Control Panel(s)

Digital Metering
 Engine Parameters
 Generator Protection Functions
 Engine Protection
 SAE J1939 Engine ECU Communications
 Windows-Based Software
 Multilingual Capability
 Remote Communications to our RDP-110 Remote Annunciator
 16 Programmable Contact Inputs
 7 Contact Outputs
 UL Recognized, cULus, CE Approved
 Event Recording
 IP 54 Front Panel Rating with Integrated Gasket
 NFPA110 Level Compatible

// Additional Features

Oil Drain Extension & S/O Valve
 Flexible Fuel Connector
 Battery Cables
 Vibration Isolation Pads
 Jacket Water Heater: -20° F
 Mainline Circuit Breaker
 UL2200 Listed
 Steel Sub-Base
 Radiator Duct Flange (OPU)
 Lube Oil & Antifreeze
 Operator's and Owner's Manual
 2 Year/3000 Hour Warranty
 Factory Tested at 0.8 PF (3 PH)

// Optional Features

Battery Charger: 6 Amp or 10 Amp
 Battery: 12 Volt w/ Rack
 Circuit Breaker: Standard or 100%
 Muffler (OPU only)
 Sub-Base Fuel Tank w/ Electrical Stub-Up Area
 Weatherproof Enclosure
 Sound Attenuation
 - 1 1/2" Foam
 - Sound Scoops
 Remote Annunciator
 Isochronous Governor

APPLICATION DATA

// Engine

Manufacturer	John Deere
Model	6068HF285
Type	4-Cycle
Arrangement	6-Inline
Displacement: L (in ³)	6.8 (415)
Bore: cm (in)	10.6 (4.19)
Stroke: cm (in)	12.7 (5)
Compression Ratio	19:1
Rated RPM	1,800
Engine Governor	JDEC
Maximum Power: Standby: kWm (bhp)	177 (237)
Speed Regulation	±0.25%
Air Cleaner	Dry

// Liquid Capacity (Lubrication)

Total Oil System: L (gal)	20 (5.28)
Engine Jacket Water Capacity: L (gal)	12.3 (3.25)
System Coolant Capacity: L (gal)	22.7 (6)

// Electrical

Electric Volts DC	12
Cold Cranking Amps Under -17.8°C (0°F)	800

// Fuel System

Fuel Supply Connection Size	3/8" NPT
Fuel Return Connection Size	3/8" NPT
Maximum Fuel Lift: m (ft)	3 (10)
Recommended Fuel	Diesel #2
Total Fuel Flow: L/hr (gal/hr)	107.2 (28.3)

// Fuel Consumption

At 100% of Power Rating: L/hr (gal/hr)	33.7 (8.9)
At 75% of Power Rating: L/hr (gal/hr)	26.1 (6.9)
At 50% of Power Rating: L/hr (gal/hr)	18.9 (5)

// Cooling - Radiator System

Ambient Capacity of Radiator: °C (°F)	50 (122)
Maximum Restriction of Cooling Air, Intake, and Discharge Side of Rad.: kPa (in. H ₂ O)	0.12 (0.5)
Water Pump Capacity: L/min (gpm)	180 (48)
Heat Rejection to Coolant: kW (BTUM)	93.5 (5,324)
Heat Rejection to Air to Air: kW (BTUM)	32 (1,821)
Heat Radiated to Ambient: kW (BTUM)	16 (922)

// Air Requirements

Aspirating: *m ³ /min (SCFM)	13.6 (480)
Air Flow Required for Rad.	
Cooled Unit: *m ³ /min (SCFM)	266 (9,394)
Air Flow Required for Heat Exchanger/Remote Rad. based on 25°F Rise: *m ³ /min (SCFM)	59 (2,080)

* Air density = 1.184 kg/m³ (0.0739 lbm/ft³)

// Exhaust System

Gas Temp. (Stack): °C (°F)	505 (941)
Gas Volume at Stack Temp: m ³ /min (CFM)	34 (1,201)
Maximum Allowable Back Pressure: kPa (in. H ₂ O)	7.5 (30)

WEIGHTS AND DIMENSIONS

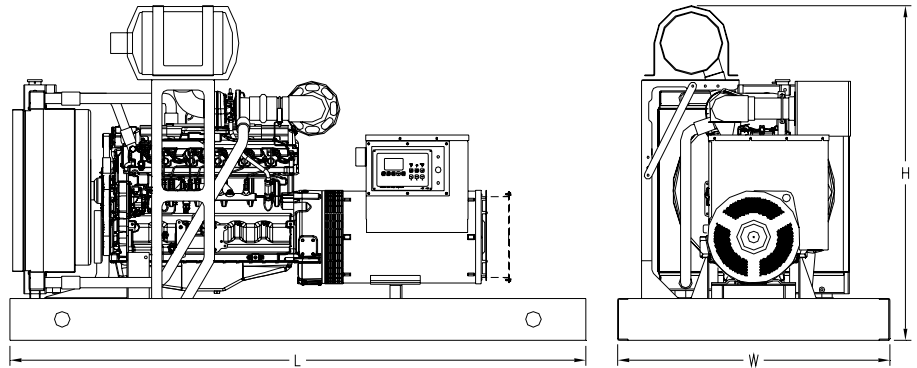

Drawing above for illustration purposes only, based on standard open power 480 volt engine-generator set. Lengths may vary with other voltages. Do not use for installation design. See website for unit specific template drawings.

System	Dimensions (L x W x H)	Height w/Tank 24hr.	Weight (less tank)
OPU	2,790 x 1,320 x 1,630 mm (110 x 52 x 64 in)	2,110 mm (82.9 in)	1,280 kg (2,821 lb)
EPU	2,790 x 1,320 x 1,960 mm (110 x 52 x 77 in)	2,460 mm (97 in)	1,535 kg (3,385 lb)

Weights and dimensions are based on open power units and are estimates only. Consult the factory for accurate weights and dimensions for your specific engine-generator set.

SOUND DATA

Unit Type	Standby Full Load	Standby No Load
OPU w/ Critical Grade Muffler (dBA)	91.5	84
Sound Attenuated Enclosure (dBA)	83.5	76

Sound data is provided at 7 m (23 ft).

EMISSIONS DATA

NO _x + NMHC	CO	PM
2.86	0.78	0.104

All units are in g/hp-hr and are EPA D2 cycle values.

Emission levels of the engine may vary as a function of ambient temperature, barometric pressure, humidity, fuel type and quality, installation parameters, measuring instrumentation, etc. The data provided are laboratory results from one engine representing this rating. The data was obtained under controlled environmental conditions with calibrated instrumentation traceable to the United States National Bureau of Standards and in compliance with US EPA regulations found within 40 CFR Part 89. The weighted cycle value from each engine is guaranteed to be below the US EPA Standards at the US EPA defined conditions.

RATING DEFINITIONS AND CONDITIONS

// Standby ratings apply to installations served by a reliable utility source. The standby rating is applicable to varying loads for the duration of a power outage. No overload capability for this rating. Ratings are in accordance with ISO-3046/1, BS 5514, AS 2789, and DIN 6271.

// Deration Factor:

Altitude: 0.5% per 305 m (1,000 ft) above 1,524 m (5,000 ft) and 4% per 305 m (1,000 ft) above 3,048 m (10,000 ft). Consult your local MTU Onsite Energy Power Generation Distributor for other altitudes.

Temperature: 0.5% per 5.5°C (10°F) above 25°C (77°F).

Materials and specifications subject to change without notice.

C/F = Consult Factory/MTU Onsite Energy Distributor