

# GAS ENGINE-GENERATOR SET

## 60-GC6NLT1

60 kWe / 60 Hz / Standby  
208 - 600V



### SYSTEM RATINGS

#### Standby

Voltage (L-L)	240V**	240V**	208V**	240V**	480V**	600V**
Phase	1	1	3	3	3	3
PF	1.0	1.0	0.8	0.8	0.8	0.8
Hz	60	60	60	60	60	60
Natural Gas						
Ratings: Amps	229	229	208	180	90	72
Natural Gas						
Ratings: kW/kVA	55/55	55/55	60/75	60/75	60/75	60/75
LP Gas						
Ratings: Amps	250	250	208	180	90	72
LP Gas						
Ratings: kW/kVA	60/60	60/60	60/75	60/75	60/75	60/75
skVA@30%						
Voltage Dip	127	230	148	148	142	140
Generator Model*	362CSL1606	362CSL1615	361CSL1602	361CSL1602	361CSL1601	361PSL1633
Temp Rise	130°C/27°C	125°C/40°C	130°C/27°C	130°C/27°C	130°C/27°C	125°C/40°C
Connection	12 LEAD ZIG-ZAG	4 LEAD	12 LEAD LOW WYE	12 LEAD HI DELTA	12 LEAD HI WYE	4 LEAD WYE

\* The Generator Model Number identified in the table is for standard C Series Configuration. Consult the factory for alternate configuration.

\*\* UL2200 Offered

### STANDARD FEATURES

- // Engine-Generator Set Tested to ISO 8528-5 for Transient Response
- // UL2200, CSA Listing Offered
- // Accepts Rated Load in One Step Per NFPA 110
- // All engine-generator sets are prototype and factory tested
- // MTU Onsite Energy is a single source supplier
- // Global Product Support
- // 2 Year Standard Warranty
- // 5.7 L Engine
  - 5.7 Liter Displacement
  - 4-Cycle
- // Integral Vibration Isolators
- // Complete Range of Accessories
- // Permanent Magnet Generator (PMG)
  - Brushless, Rotating Field
  - 300% Short Circuit Capability
  - 2/3 Pitch Windings
  - Standard for 570 frame and larger
  - Optional for 430 frame and smaller
- // Digital Control Panel(s)
  - UL Recognized, cULus, NFPA 110
  - Complete System Metering
  - LCD Display
- // Cooling System
  - Integral Set-mounted
  - Engine Driven Fan

## STANDARD EQUIPMENT

---

### // Engine

Air Cleaner  
 Oil Pump  
 Full Flow Oil Filter  
 Jacket Water Pump  
 Thermostat  
 Exhaust Manifold – Dry  
 Blower Fan & Fan Drive  
 Radiator - Unit Mounted  
 Electric Starting Motor - 12V  
 Governor – Electric Isochronous  
 Base - Formed Steel  
 SAE Flywheel & Bell Housing  
 Charging Alternator - 12V  
 Battery Box & Cables  
 Flexible Fuel Connectors  
 Flexible Exhaust Connection  
 EPA Certified Engine

### // Generator

NEMA MG1, IEEE and ANSI standards compliance for temperature rise and motor starting  
 Sustained short circuit current of up to 300% of the rated current for up to 10 seconds  
 Self-Ventilated and Drip-Proof  
 Superior Voltage Waveform  
 Digital, Solid State, Volts-per-Hertz Regulator  
 No Load to Full Load Regulation  
 Brushless Alternator with Brushless Pilot Exciter  
 4 Pole, Rotating Field  
 130°C Standby Temperature Rise  
 1 Bearing, Sealed  
 Flexible Coupling  
 Full Amortisseur Windings  
 125% Rotor Balancing  
 3-Phase Voltage Sensing  
 ±1% Voltage Regulation  
 100% of Rated Load - One Step  
 3% Maximum Harmonic Content

### // Digital Control Panel(s)

Digital Metering  
 Engine Parameters  
 Generator Protection Functions  
 Engine Protection  
 SAE J1939 Engine ECU Communications  
 Windows-Based Software  
 Multilingual Capability  
 Remote Communications to our RDP-110 Remote Annunciator  
 16 Programmable Contact Inputs  
 7 Contact Outputs  
 UL Recognized,  us, CE Approved  
 Event Recording  
 IP 54 Front Panel Rating with Integrated Gasket  
 NFPA110 Level Compatible

## APPLICATION DATA

### // Engine

Manufacturer	GM
Model	5.7L
Type	4-Cycle
Arrangement	8-V
Displacement: L (in <sup>3</sup> )	5.7 (350)
Bore: cm (in)	10.2 (4)
Stroke: cm (in)	8.8 (3.5)
Compression Ratio	9.4:1
Rated RPM	1,800
Engine Governor	Bosch
Maximum Power: Standby: kWm (bhp)	84.4 (113.2)
Speed Regulation	±1%
Air Cleaner	Dry

### // Liquid Capacity (Lubrication)

Total Oil System: L (gal)	4.9 (1.3)
Engine Jacket Water Capacity: L (gal)	8.7 (2.3)
System Coolant Capacity: L (gal)	22.7 (6)

### // Electrical

Electric Volts DC	12
Cold Cranking Amps Under -17.8°C (0°F)	600

### // Fuel Inlet

Fuel Supply Connection Size	1 1/2" NPT
Fuel Supply Pressure: mm H <sub>2</sub> O (in. H <sub>2</sub> O)	178–279 (7–11)

### // Fuel Consumption (NG-1000 BTU/ft<sup>3</sup> / LP-2500 BTU/ft<sup>3</sup>)

	NG	LPG
At 100% of Power Rating: m <sup>3</sup> /hr (ft <sup>3</sup> /hr)	20.3 (717)	9 (317)
At 75% of Power Rating: m <sup>3</sup> /hr (ft <sup>3</sup> /hr)	15.3 (541)	6.8 (239)
At 50% of Power Rating: m <sup>3</sup> /hr (ft <sup>3</sup> /hr)	10.6 (376)	4.7 (166)

### // Cooling - Radiator System

Ambient Capacity of Radiator: °C (°F)	50 (122)
Maximum Restriction of Cooling Air, Intake, and Discharge Side of Rad.: kPa (in. H <sub>2</sub> O)	0.12 (0.5)
Water Pump Capacity: L/min (gpm)	113.6 (30)
Heat Rejection to Coolant: kW (BTUM)	59.8 (3,400)
Heat Radiated to Ambient: kW (BTUM)	17.5 (993.2)

### // Air Requirements

Aspirating: *m <sup>3</sup> /min (SCFM)	5.2 (182.3)
Air Flow Required for Rad.	
Cooled Unit: *m <sup>3</sup> /min (SCFM)	209.4 (7,396)
Air Flow Required for Heat Exchanger/Remote Rad. based on 25°F Rise: *m <sup>3</sup> /min (SCFM)	63.4 (2,240)

\* Air density = 1.184 kg/m<sup>3</sup> (0.0739 lbm/ft<sup>3</sup>)

### // Exhaust System

Gas Temp. (Stack): °C (°F)	704.4 (1,300)
Gas Volume at Stack Temp: m <sup>3</sup> /min (CFM)	16.7 (588.7)
Maximum Allowable Back Pressure: kPa (in. H <sub>2</sub> O)	10 (40)

## WEIGHTS AND DIMENSIONS

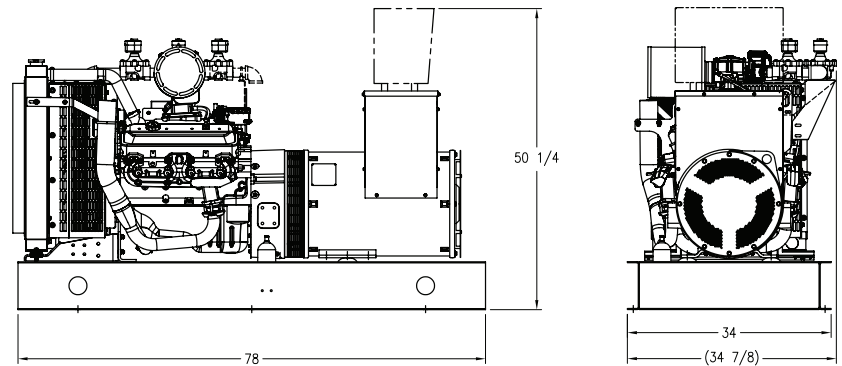

Drawing above for illustration purposes only, based on standard open power 480 volt engine-generator set. Lengths may vary with other voltages. Do not use for installation design. See website for unit specific template drawings.

System	Dimensions (L x W x H)	Weight (dry)
OPU	1,981 x 864 x 1,276 mm (78 x 34 x 50.25 in)	658 kg (1,450 lb)

Weights and dimensions are based on open power units and are estimates only. Consult the factory for accurate weights and dimensions for your specific engine-generator set.

## SOUND DATA

Unit Type	Standby Full Load	Standby No Load
OPU (dBA)	C/F	C/F
WPE - No Sound Attenuation (dBA)	C/F	C/F
CQE (dBA)	C/F	C/F

Sound data is provided at 7m (23 ft).

## EMISSIONS DATA

Fuel Type	THC + NO <sub>x</sub>	CO
Natural Gas	10.34	35.82
Liquid Propane	12.94	39.68

All units are in g/hp-hr.

Engine meets EPA 40 CFR Part 60/90 specifications.

## RATING DEFINITIONS AND CONDITIONS

// Standby ratings apply to installations served by a reliable utility source. The standby rating is applicable to varying loads for the duration of a power outage. No overload capability for this rating. Ratings are in accordance with ISO-3046/1, BS 5514, AS 2789, and DIN 6271.

// Deration Factor:

**Altitude:** 3% per 305 m (1,000 ft) above 100 m (328 ft). Consult your local MTU Onsite Energy Power Generation Distributor for other altitudes.

**Temperature:** 1% per 5.5°C (10°F) above 25°C (77°F).

Materials and specifications subject to change without notice.

C/F = Consult Factory/MTU Onsite Energy Distributor