

DIESEL ENGINE-GENERATOR SET

900-XC6DT2

900 kWe / 60 Hz / Standby
800 kWe / 60 Hz / Prime
208 - 4160V



SYSTEM RATINGS

Standby

Voltage (L-L)	208V**	240V**	480V**	600V**	4160V
Phase	3	3	3	3	3
PF	0.8	0.8	0.8	0.8	0.8
Hz	60	60	60	60	60
kW	900	900	900	900	900
kVA	1125	1125	1125	1125	1125
AMPS	3123	2706	1353	1083	156
skVA@30%					
Voltage Dip	2600	2600	2500	2850	1950
Generator Model*	741RSL4045	741RSL4045	574RSL4038	574RSS4280	741FSM4360
Temp Rise	130°C/27°C	130°C/27°C	130°C/27°C	125°C/40°C	130°C/27°C
Connection	12 LEAD LOW WYE	12 LEAD HI DELTA	4 LEAD WYE	4 LEAD WYE	6 LEAD WYE

Prime

Voltage (L-L)	208V	240V	480V	600V	4160V
Phase	3	3	3	3	3
PF	0.8	0.8	0.8	0.8	0.8
Hz	60	60	60	60	60
kW	800	800	800	800	800
kVA	1000	1000	1000	1000	1000
AMPS	2776	2406	1203	962	139
skVA@30%					
Voltage Dip	2600	2600	2500	2850	1950
Generator Model*	741RSL4045	741RSL4045	574RSL4037	574RSS4280	741FSM4360
Temp Rise	105°C/40°C	105°C/40°C	105°C/40°C	105°C/40°C	105°C/40°C
Connection	12 LEAD LOW WYE	12 LEAD HI DELTA	12 LEAD HI WYE	4 LEAD WYE	6 LEAD WYE

* The Generator Model Number identified in the table is for standard C Series Configuration. Consult the factory for alternate configuration.

** UL2200 Offered

STANDARD FEATURES

- // EPA Tier 2 Certified
- // Engine-Generator Set Tested to ISO 8528-5 for Transient Response
- // UL2200, CSA Listing Offered
- // Accepts Rated Load in One Step Per NFPA 110
- // All engine-generator sets are prototype and factory tested
- // MTU Onsite Energy is a single source supplier
- // Global Product Support
- // 2 Year Standard Warranty
- // 16V 2000 Diesel Engine
 - 31.8 Liter Displacement
 - Electronic Unit Pump Injection
 - 4-Cycle
- // Complete Range of Accessories
- // Permanent Magnet Generator (PMG)
 - Brushless, Rotating Field
 - 300% Short Circuit Capability
 - 2/3 Pitch Windings
 - Standard for 570 frame and larger
 - Optional for 430 frame and smaller
- // Digital Control Panel(s)
 - UL Recognized, c  us, NFPA 110
 - Complete System Metering
 - LCD Display
- // Cooling System
 - Integral Set-Mounted
 - Engine Driven Fan

STANDARD EQUIPMENT

// Engine

.....
 Air Cleaners
 Oil Pump
 Full Flow Oil Filter
 Closed Crankcase Ventilation
 Jacket Water Pump
 Inter Cooler Water Pump
 Thermostats
 Exhaust Manifold - Dry
 Blower Fan & Fan Drive
 Radiator - Unit Mounted
 Electric Starting Motor - 24V
 Governor - Electronic Isochronous
 Base - Structural Steel
 SAE Flywheel & Bell Housing
 Charging Alternator - 24V
 Battery Box & Cables
 Flexible Fuel Connectors
 Flexible Exhaust Connection
 EPA Certified Engine

// Generator

.....
 NEMA MG1, IEEE and ANSI standards compliance for temperature rise and motor starting
 Sustained short circuit current of up to 300% of the rated current for up to 10 seconds
 Self-Ventilated and Drip-Proof
 Superior Voltage Waveform
 Digital, Solid State, Volts-per-Hertz Regulator

.....
 No Load to Full Load Regulation
 Brushless Alternator with Brushless Pilot Exciter
 4 Pole, Rotating Field
 130°C Standby Temperature Rise
 1 Bearing, Sealed
 Flexible Coupling
 Full Amortisseur Windings
 125% Rotor Balancing
 3-Phase Voltage Sensing
 ±0.25% Voltage Regulation
 100% of Rated Load - One Step
 3% Maximum Harmonic Content

// Digital Control Panel(s)

.....
 Digital Metering
 Engine Parameters
 Generator Protection Functions
 Engine Protection
 SAE J1939 Engine ECU Communications
 Windows-Based Software
 Multilingual Capability
 Remote Communications to our RDP-110 Remote Annunciator
 16 Programmable Contact Inputs
 7 Contact Outputs
 UL Recognized, c  us, CE Approved
 Event Recording
 IP 54 Front Panel Rating with Integrated Gasket
 NFPA110 Level Compatible

APPLICATION DATA

// Engine

Manufacturer	MTU
Model	16V 2000 G45TB
Type	4-Cycle
Arrangement	16-V
Displacement: L (in ³)	31.8 (1,943)
Bore: cm (in)	13 (5.1)
Stroke: cm (in)	15 (5.9)
Compression Ratio	16:1
Rated RPM	1,800
Engine Governor	Electronic Isochronous (ADEC)
Maximum Power: Standby: kWm (bhp)	1,010 (1,354)
Maximum Power: Prime: kWm (bhp)	915 (1,227)
Speed Regulation	±0.25%
Air Cleaner	Dry

// Liquid Capacity (Lubrication)

Total Oil System: L (gal)	102 (26.9)
Engine Jacket Water Capacity: L (gal)	130 (34.3)
After Cooler Water Capacity: L (gal)	20 (5.3)
System Coolant Capacity: L (gal)	415 (110)

// Electrical

Electric Volts DC	24
Cold Cranking Amps Under -17.8°C (0°F)	1,900

// Fuel System

Fuel Supply Connection Size	3/4" NPT
Fuel Return Connection Size	1/4" NPT
Maximum Fuel Lift: m (ft)	3 (10)
Recommended Fuel	Diesel #2
Total Fuel Flow: L/hr (gal/hr)	480.7 (127)

// Fuel Consumption

	STANDBY	PRIME
At 100% of Power Rating: L/hr (gal/hr)	243.4 (64.3)	221.4 (58.5)
At 75% of Power Rating: L/hr (gal/hr)	186.2 (49.2)	169.2 (44.7)
At 50% of Power Rating: L/hr (gal/hr)	126.4 (33.4)	115.4 (30.5)

// Cooling - Radiator System

	STANDBY	PRIME
Ambient Capacity of Radiator: °C (°F)	50 (122)	50 (122)
Maximum Restriction of Cooling Air, Intake, and Discharge Side of Rad.: kPa (in. H ₂ O)	0.12 (0.5)	0.12 (0.5)
Water Pump Capacity: L/min (gpm)	833 (220)	833 (220)
After Cooler Pump Capacity: L/min (gpm)	257 (68)	257 (68)
Heat Rejection to Coolant: kW (BTUM)	355 (20,188)	320 (18,197)
Heat Rejection to After Cooler: kW (BTUM)	290 (16,491)	265 (15,070)
Heat Radiated to Ambient: kW (BTUM)	97.4 (5,539)	92.5 (5,260)

// Air Requirements

	STANDBY	PRIME
Aspirating: *m ³ /min (SCFM)	84 (2,966)	81 (2,860)
Air Flow Required for Rad. Cooled Unit: *m ³ /min (SCFM)	1,133 (40,013)	1,133 (40,013)
Air Flow Required for Heat Exchanger/Remote Rad. based on 25°F Rise: *m ³ /min (SCFM)	354 (12,490)	336 (11,863)

* Air density = 1.184 kg/m³ (0.0739 lbm/ft³)

// Exhaust System

	STANDBY	PRIME
Gas Temp. (Stack): °C (°F)	530 (986)	520 (968)
Gas Volume at Stack Temp: m ³ /min (CFM)	210 (7,416)	190 (6,780)
Maximum Allowable Back Pressure: kPa (in. H ₂ O)	8.5 (34.1)	8.5 (34.1)

WEIGHTS AND DIMENSIONS

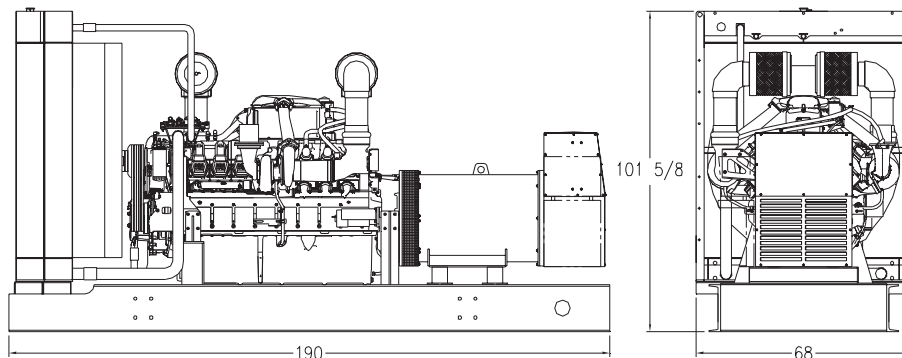

Drawing above for illustration purposes only, based on standard open power 480 volt engine-generator set. Lengths may vary with other voltages. Do not use for installation design. See website for unit specific template drawings.

System

OPU

Dimensions (L x W x H)

5,010 x 1,940 x 2,600 mm (197.4 x 76.5 x 102.5 in)

Weight (less tank)

7,733 kg (17,047 lb)

Weights and dimensions are based on open power units and are estimates only. Consult the factory for accurate weights and dimensions for your specific engine-generator set.

SOUND DATA

Unit Type	Standby Full Load	Standby No Load	Prime Full Load	Prime No Load
OPU w/Critical Grade Muffler (dBA)	101	94	99.5	94
Sound Attenuated Enclosure (dBA)	93	86	91.5	86

Sound data is provided at 7 m (23 ft).

EMISSIONS DATA

NO_x + NMHC	CO	PM
5.5	1.44	0.131

All units are in g/hp-hr and are EPA D2 cycle values.

Emission levels of the engine may vary as a function of ambient temperature, barometric pressure, humidity, fuel type and quality, installation parameters, measuring instrumentation, etc. The data provided are laboratory results from one engine representing this rating. The data was obtained under controlled environmental conditions with calibrated instrumentation traceable to the United States National Bureau of Standards and in compliance with US EPA regulations found within 40 CFR Part 89. The weighted cycle value from each engine is guaranteed to be below the US EPA Standards at the US EPA defined conditions.

Materials and specifications subject to change without notice.

C/F = Consult Factory/MTU Onsite Energy Distributor

RATING DEFINITIONS AND CONDITIONS

- // Standby ratings apply to installations served by a reliable utility source. The standby rating is applicable to varying loads for the duration of a power outage. No overload capability for this rating. Ratings are in accordance with ISO-3046/1, BS 5514, AS 2789, and DIN 6271.
- // Prime power ratings apply to installations where utility power is unavailable or unreliable. At varying load, the number of generator set operating hours is unlimited. A 10% overload capacity is available for one hour in twelve. Ratings are in accordance with ISO-8528/1, overload power in accordance with ISO-3046/1, BS 5514, AS 2789, and DIN 6271. For limited running time and base load ratings, consult the factory.
- // Deration Factor:
 - Altitude:** No derate with increased altitude at 25°C (77°F). Maximum altitude 3,000 m (9,843 ft). Consult your local MTU Onsite Energy Power Generation Distributor for other altitudes.
 - Temperature:** No derate with increased temperature at 100 m (328 ft). Maximum ambient temperature 50°C (122°F).