

# DIESEL ENGINE-GENERATOR SET

## 100-JC6DT3

100 kWe / 60 Hz / Standby  
90 kWe / 60 Hz / Prime  
208 - 600V



### SYSTEM RATINGS

#### Standby

Voltage (L-L)	240V**	240V**	208V**	240V**	480V**	600V**
Phase	1	1	3	3	3	3
PF	1.0	1.0	0.8	0.8	0.8	0.8
Hz	60	60	60	60	60	60
kW	100	100	100	100	100	100
kVA	100	100	125	125	125	125
AMPS	417	417	347	301	150	120
skVA@30%						
Voltage Dip	108	311	205	205	230	270
Generator Model*	431CSL6202	363CSL1617	362CSL1606	362CSL1606	362CSL1606	362PSL1636
Temp Rise	130°C/27°C	130°C/27°C	130°C/27°C	130°C/27°C	130°C/27°C	125°C/40°C
Connection	12 LEAD ZIG-ZAG	4 LEAD	12 LEAD LOW WYE	12 LEAD HI DELTA	12 LEAD HI WYE	4 LEAD WYE

#### Prime

Voltage (L-L)	240V	240V	208V	240V	480V	600V
Phase	1	1	3	3	3	3
PF	1.0	1.0	0.8	0.8	0.8	0.8
Hz	60	60	60	60	60	60
kW	90	90	90	90	90	90
kVA	90	90	112.5	112.5	112.5	112.5
AMPS	375	375	312	271	135	108
skVA@30%						
Voltage Dip	108	311	205	205	270	270
Generator Model*	431CSL6202	363CSL1617	362CSL1606	362CSL1606	362CSL1606	362PSL1636
Temp Rise	105°C/40°C	105°C/40°C	105°C/40°C	105°C/40°C	105°C/40°C	105°C/40°C
Connection	12 LEAD ZIG-ZAG	4 LEAD	12 LEAD LOW WYE	12 LEAD HI DELTA	12 LEAD HI WYE	4 LEAD WYE

\* The Generator Model Number identified in the table is for standard C Series Configuration. Consult the factory for alternate configuration.

\*\* UL2200 Offered

## STANDARD FEATURES

- // EPA Tier 3 Certified
- // Engine-Generator Set Tested to ISO 8528-5 for Transient Response
- // UL2200, CSA Listing Offered
- // Accepts Rated Load in One Step Per NFPA 110
- // All engine-generator sets are prototype and factory tested
- // MTU Onsite Energy is a single source supplier
- // Global Product Support
- // 2 Year Standard Warranty
- // 4045HF285 Diesel Engine
  - 4.5 Liter Displacement
  - 4-Cycle
- // Complete Range of Accessories
- // Permanent Magnet Generator (PMG)
  - Brushless, Rotating Field
  - 300% Short Circuit Capability
  - 2/3 Pitch Windings
  - Standard for 570 frame and larger
  - Optional for 430 frame and smaller
- // Digital Control Panel(s)
  - UL Recognized,  us, NFPA 110
  - Complete System Metering
  - LCD Display
- // Cooling System
  - Integral Set-Mounted
  - Engine Driven Fan

## STANDARD EQUIPMENT

### // Engine

Air Cleaner  
 Oil Pump  
 Full Flow Oil Filter  
 Fuel Filter with Water Separator  
 Jacket Water Pump  
 Thermostats  
 Exhaust Manifold - Dry  
 Blower Fan & Fan Drive  
 Radiator - Unit Mounted  
 Electric Starting Motor - 12V  
 Governor - Electronic Isochronous  
 Base - Formed Steel  
 SAE Flywheel & Bell Housing  
 Charging Alternator - 12V  
 Battery Box & Cables  
 Flexible Fuel Connectors  
 Flexible Exhaust Connection  
 EPA Certified Engine

### // Generator

NEMA MG1, IEEE and ANSI standards compliance for temperature rise and motor starting  
 Sustained short circuit current of up to 300% of the rated current for up to 10 seconds  
 Self-Ventilated and Drip-Proof  
 Superior Voltage Waveform  
 Digital, Solid State, Volts-per-Hertz Regulator  
 No Load to Full Load Regulation

Brushless Alternator with Brushless Pilot Exciter  
 4 Pole, Rotating Field  
 130°C Standby Temperature Rise  
 1 Bearing, Sealed  
 Flexible Coupling  
 Full Amortisseur Windings  
 125% Rotor Balancing  
 3-Phase Voltage Sensing  
 ± 1% Voltage Regulation  
 100% of Rated Load - One Step  
 3% Maximum Harmonic Content

### // Digital Control Panel(s)

Digital Metering  
 Engine Parameters  
 Generator Protection Functions  
 Engine Protection  
 SAE J1939 Engine ECU Communications  
 Windows-Based Software  
 Multilingual Capability  
 Remote Communications to our RDP-110 Remote Annunciator  
 16 Programmable Contact Inputs  
 7 Contact Outputs  
 UL Recognized,  us, CE Approved  
 Event Recording  
 IP 54 Front Panel Rating with Integrated Gasket  
 NFPA110 Level Compatible

## APPLICATION DATA

### // Engine

Manufacturer	John Deere
Model	4045HF285
Type	4-Cycle
Arrangement	4-Inline
Displacement: L (in <sup>3</sup> )	4.5 (275)
Bore: cm (in)	10.6 (4.19)
Stroke: cm (in)	12.7 (8)
Compression Ratio	19:1
Rated RPM	1,800
Engine Governor	JDEC
Maximum Power: Standby: kWm (bhp)	118 (158)
Maximum Power: Prime: kWm (bhp)	107 (144)
Speed Regulation	±0.25%
Air Cleaner	Dry

### // Liquid Capacity (Lubrication)

Total Oil System: L (gal)	12 (3.2)
Engine Jacket Water Capacity: L (gal)	12.5 (3.3)
System Coolant Capacity: L (gal)	20.1 (5.3)

### // Electrical

Electric Volts DC	12
Cold Cranking Amps Under -17.8°C (0°F)	800

### // Fuel System

Fuel Supply Connection Size	3/8" NPT
Fuel Return Connection Size	3/8" NPT
Maximum Fuel Lift: m (ft)	3 (10)
Recommended Fuel	Diesel #2
Total Fuel Flow: L/hr (gal/hr)	74.6 (19.7)

### // Fuel Consumption

	STANDBY	PRIME
At 100% of Power Rating: L/hr (gal/hr)	31 (8.2)	28 (7.4)
At 75% of Power Rating: L/hr (gal/hr)	25 (6.6)	22.3 (5.9)
At 50% of Power Rating: L/hr (gal/hr)	17.8 (4.7)	15.9 (4.2)

### // Cooling - Radiator System

	STANDBY	PRIME
Ambient Capacity of Radiator: °C (°F)	50 (122)	50 (122)
Maximum Restriction of Cooling Air, Intake, and Discharge Side of Rad.: kPa (in. H <sub>2</sub> O)	0.12 (0.5)	0.12 (0.5)
Water Pump Capacity: L/min (gpm)	180 (48)	180 (48)
Heat Rejection to Coolant: kW (BTUM)	62 (3,544)	56 (3,190)
Heat Rejection to Air to Air: kW (BTUM)	19.8 (1,127)	17.6 (1,002)
Heat Radiated to Ambient: kW (BTUM)	16.2 (919)	13.8 (785)

### // Air Requirements

	STANDBY	PRIME
Aspirating: *m <sup>3</sup> /min (SCFM)	8.2 (288)	7.7 (273)
Air Flow Required for Rad.		
Cooled Unit: *m <sup>3</sup> /min (SCFM)	188 (6,635)	188 (6,635)
Air Flow Required for Heat Exchanger/Remote Rad. based on 25°F Rise: *m <sup>3</sup> /min (SCFM)	59 (2,074)	50 (1,771)

\* Air density = 1.184 kg/m<sup>3</sup> (0.0739 lbm/ft<sup>3</sup>)

### // Exhaust System

	STANDBY	PRIME
Gas Temp. (Stack): °C (°F)	580 (1,076)	560 (1,040)
Gas Volume at Stack		
Temp: m <sup>3</sup> /min (CFM)	22.8 (805)	21.2 (750)
Maximum Allowable		
Back Pressure: kPa (in. H <sub>2</sub> O)	7.5 (30)	7.5 (30)

## WEIGHTS AND DIMENSIONS

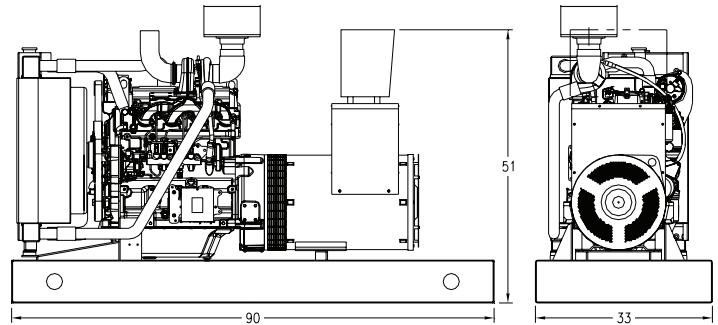

Drawing above for illustration purposes only, based on standard open power 480 volt engine-generator set. Lengths may vary with other voltages. Do not use for installation design. See website for unit specific template drawings.

System	Dimensions (L x W x H)	Weight (less tank)
OPU	2,290 x 840 x 1,300 mm (90 x 33 x 51 in)	1,073 kg (2,365 lb)

Weights and dimensions are based on open power units and are estimates only. Consult the factory for accurate weights and dimensions for your specific engine-generator set.

## SOUND DATA

Unit Type	Standby Full Load	Standby No Load	Prime Full Load	Prime No Load
OPU w/Critical Grade Muffler (dBA)	91	83	89.5	83
Sound Attenuated Enclosure (dBA)	83	75	81.5	75

Sound data is provided at 7 m (23 ft).

## EMISSIONS DATA

NO <sub>x</sub> + NMHC	CO	PM
2.56	1.1	0.18

### All units are in g/hp-hr and are EPA D2 cycle values.

Emission levels of the engine may vary as a function of ambient temperature, barometric pressure, humidity, fuel type and quality, installation parameters, measuring instrumentation, etc. The data provided are laboratory results from one engine representing this rating. The data was obtained under controlled environmental conditions with calibrated instrumentation traceable to the United States National Bureau of Standards and in compliance with US EPA regulations found within 40 CFR Part 89. The weighted cycle value from each engine is guaranteed to be below the US EPA Standards at the US EPA defined conditions.

## RATING DEFINITIONS AND CONDITIONS

- // Standby ratings apply to installations served by a reliable utility source. The standby rating is applicable to varying loads for the duration of a power outage. No overload capability for this rating. Ratings are in accordance with ISO-3046/1, BS 5514, AS 2789, and DIN 6271.
- // Prime power ratings apply to installations where utility power is unavailable or unreliable. At varying load, the number of generator set operating hours is unlimited. A 10% overload capacity is available for one hour in twelve. Ratings are in accordance with ISO-8528/1, overload power in accordance with ISO-3046/1, BS 5514, AS 2789, and DIN 6271. For limited running time and base load ratings, consult the factory.
- // Deration Factor:
  - Altitude:** 0.5% per 305 m (1,000 ft) above 1,524 m (5,000 ft) and 4% per 305 m (1,000 ft) above 2,286 m (7,500 ft). Consult your local MTU Onsite Energy Power Generation Distributor for other altitudes.
  - Temperature:** 0.5% per 5.5°C (10°F) above 25°C (77°F).

Materials and specifications subject to change without notice.

C/F = Consult Factory/MTU Onsite Energy Distributor