

- NOTES:
 1. HOUSING, SCOOPS, & EXHAUST SYSTEM NOT SHOWN IN TOP VIEW
 2. FUEL INLET CONNECTION SIZE: 3/4" NPT

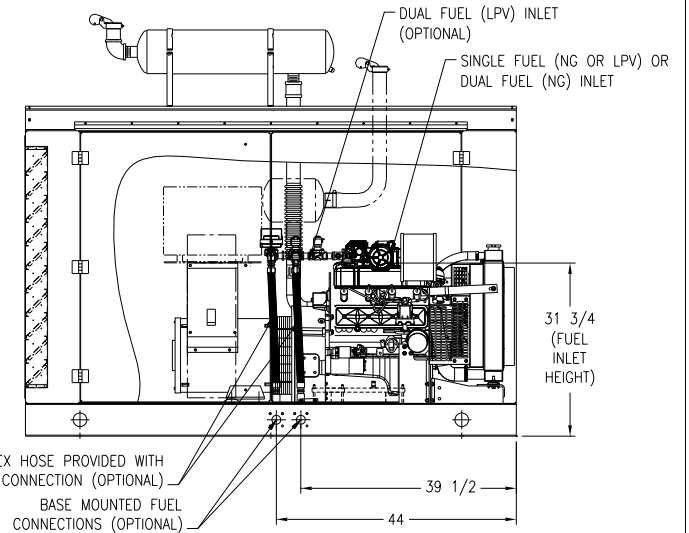

DRAWING TOLERANCES: ±1/4"
 EXCEPT BASE MTG. HOLES: ±1/8"

REVISION	DATE	REVISION DESCRIPTION	INITIALS
E	2/8/10	CORRECTED BREAKER SIZING	MTH
D	12-23-09	MOVED CONTRL PANEL / BATTERY	KAP
C	12-16-09	UPDATED TEMPLATE WITH NEW HOUSING AND BASE	JTG
B	10-20-09	UPDATED FUEL SYSTEM	MTH
A	7-14-09	INITIAL RELEASE TO SALES AND ENGINEERING	KAP

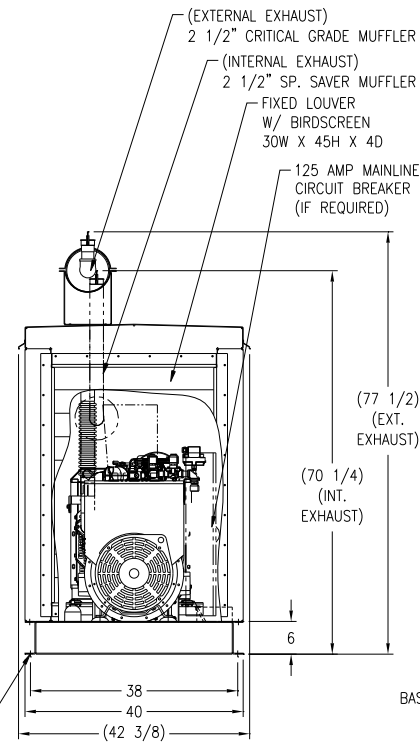
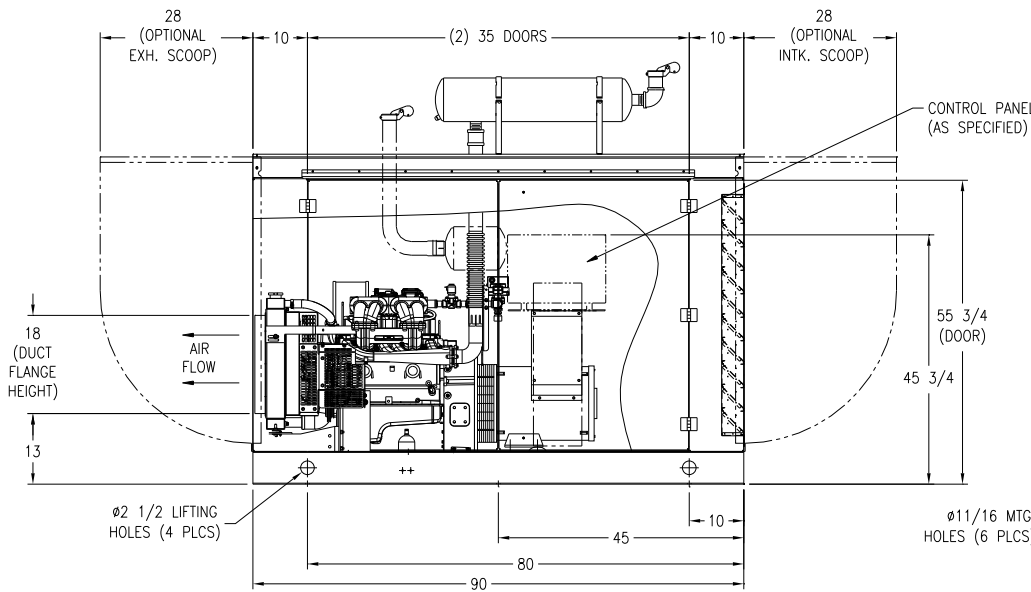
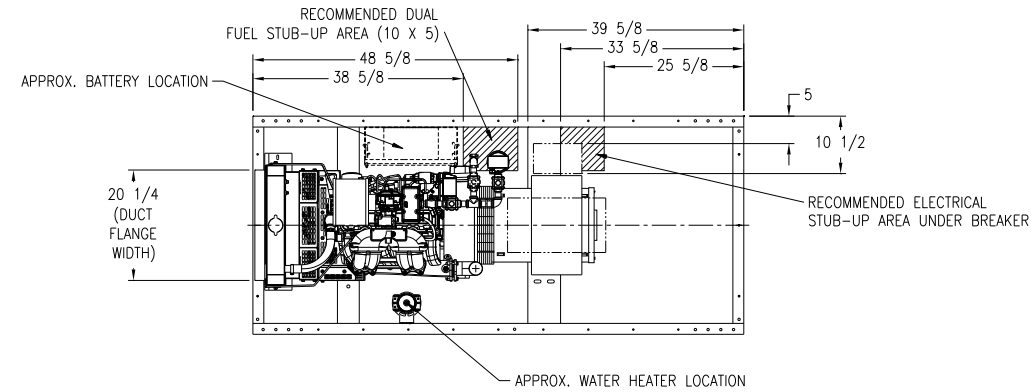

THIS DRAWING IS PROPERTY OF MTU ONSITE ENERGY CORPORATION AND CANNOT BE USED EXCEPT IN CONNECTION WITH MTU ONSITE ENERGY CORPORATION POWER GENERATION PROJECTS. ANY THIRD PARTY MODIFICATION MAY VOID THIS DRAWING. MTU ONSITE ENERGY CORPORATION RESERVES ALL RIGHTS OF THIS DRAWING.

GEN-SET INFORMATION	
ENGINE: 3.0L GM	ENCLOSURE: 95504
GENERATOR: 284	BREAKER: 100 AMP
RADIATOR: W/ ENG.	TANK: NA
RADIATOR AMBIENT: 50C	MUFFLER: SEE DRAWING
DUCT FLANGE: 105-1351	TRAILER: NA
CONTROL PANEL: AS SPECIFIED	ISOLATORS: PADS
BASE: 105-6021	

DIMENSIONAL LAYOUT	
DRAWN TO SCALE ALL DIMENSIONS ARE IN INCHES	MODEL: 30PGC6NLT1
DATE: 7-14-09	DRAWN BY: KAP
DWG. #: 30PGC6NLT1(3.0)WPF-MI	